

MDL-III-520/1~800mW



**GREEN DIODE LASER  
AT 520 nm**

Green diode laser module at 520 nm is made features of ultra compact, long lifetime, cost-effectiveness and easy operating, which can be widely used in laser projection, laser shows, biomedical applications, holography, metrology. etc.



SPECIFICATIONS

Wavelength (nm)	520±10	
Operating mode	CW	
Output power (mW)	>1, 100, 200, ..., 800	
Power stability (rms, over 4 hours)	<1%, <3%, <5%	
Transverse mode	Multimode	
Beam diameter at the aperture ((1/e <sup>2</sup> ),mm)	~1.0×3.0	
Beam divergence, full angle (mrad)	<4.0×0.5	
Warm-up time (minutes)	<5	
Beam height from base plate (mm)	24.8	
Operating temperature (°C)	10~35	
Power supply	85-264VAC	PSU-III-LED/ PSU-III-FDA (Frequency for 1Hz-30kHz)
	100-240VAC	PSU-A-D (Frequency for 30kHz -100kHz)
TTL / Analog modulation	TTL or Analog with 1Hz-1kHz 1kHz-10kHz, 10kHz-30kHz, 30kHz-100kHz optional	
Expected lifetime (hours)	10000	
Warranty	1 year	

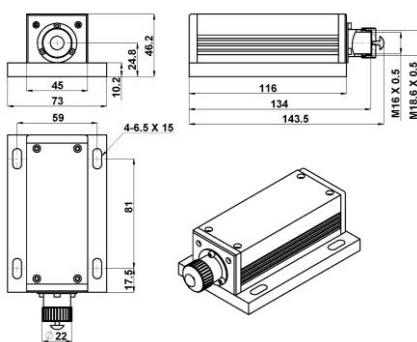
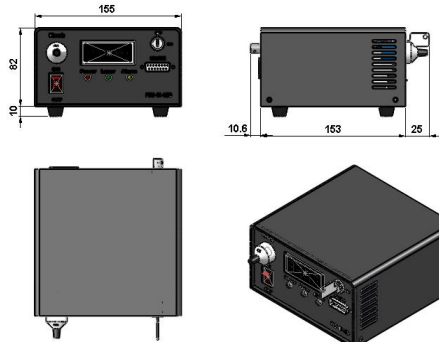
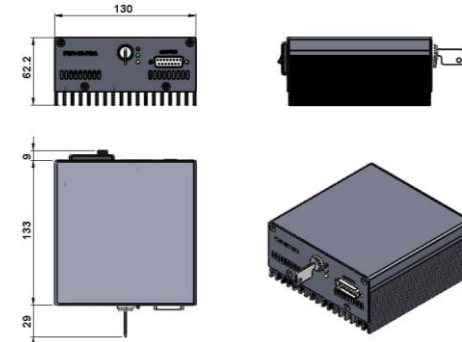
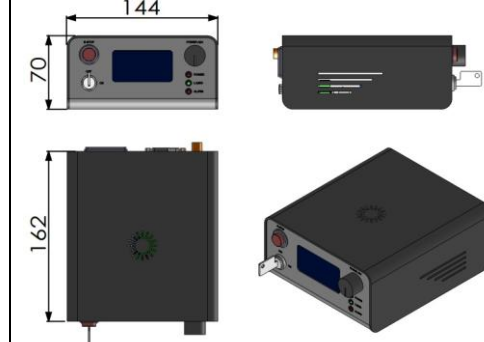

MxL-III-520	PSU-III-LED	PSU-III-FDA	PSU-A-D
 <p>143.5(L)×73(W) ×46.2(H) mm<sup>3</sup>, 0.7kg</p>	 <p>188.6 (L) ×155(W) ×92 (H) mm<sup>3</sup>, 1.5kg</p>	 <p>171(L) ×130(W) ×62.2 (H) mm<sup>3</sup>, 1.2kg</p>	 <p>162(L) ×144(W) ×70 (H) mm<sup>3</sup>, 1.0kg</p>