

HPL-1064-QS/100~150W

**WATER COOLING LD PUMPED  
ALL-SOLID-STATE  
1064nm LASER**

All solid state 1064nm infrared laser is made features of high peak power, high repetition rate, and short pulse duration, which is widely used in communication, military, laser medical treatment, scientific experiment, etc.



SPECIFICATIONS

Wavelength (nm)	1064±1
Average power (W)	100, 110, 120, ..., 150
Operating mode	Pulse (Q-switched)
Power stability (rms, over 4 hours)	<3%, <5%
Rep. rate (kHz)	10
Pulse duration (ns)	~7
Single pulse energy (mJ)	15@10kHz, 150W
Peak power (MW)	~2@10kHz, 150W
Beam divergence, full angle (mrad)	<200
Beam diameter at the aperture (mm)	~19.0
Beam height from base plate (mm)	95.0
Operating temperature (°C)	10~35
Power supply (90-264VAC)	PSU-HPL-QS (12U)
Expected lifetime (hours)	10000
Warranty period	1 year

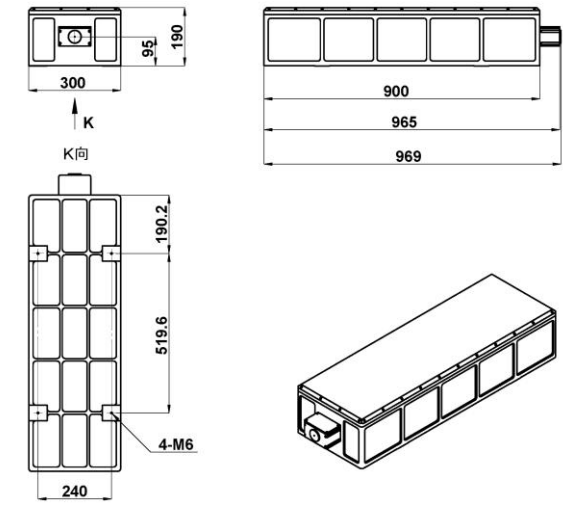
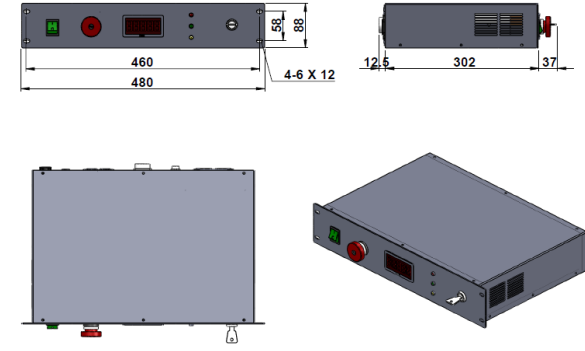
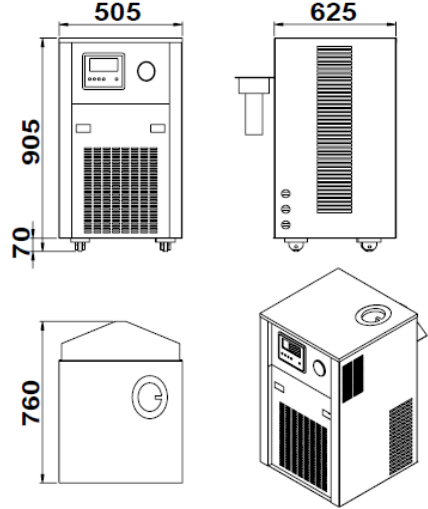

HPL-1064-QS	PSU-HPL-QS (12U)	Water chiller
 <p>969(L)×300(W)×190(H) mm<sup>3</sup>, 70kg</p>	 <p>PSU-HPL-QS(12U)-1 480 (L) × 351.5(W) × 88(H)mm<sup>3</sup>, 13kg</p>	 <p>Water chiller 1 505 (L)×760(W)×905(H)mm<sup>3</sup>, 95kg</p>

PSU-HPL-QS(12U)

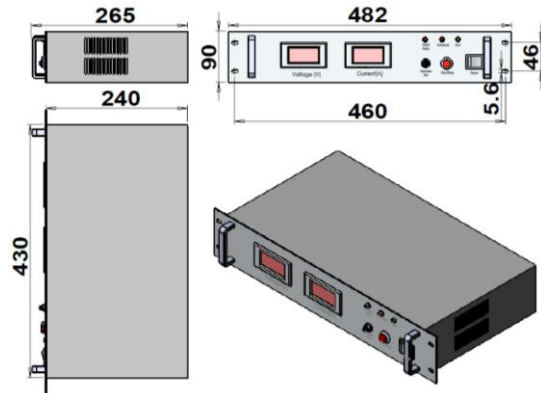

PSU-HPL-QS(12U)-4 482(L) × 265(W) × 90(H)mm<sup>3</sup>, 13kg

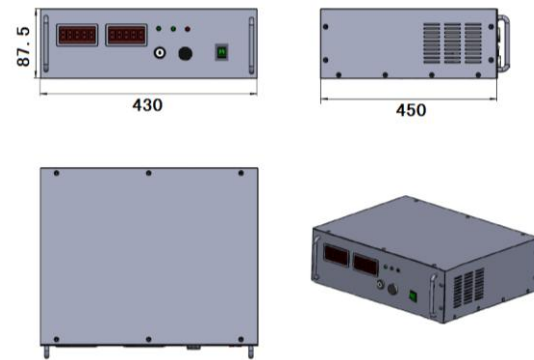

PSU-HPL-QS(12U)-5 430(L) × 450(W) × 87.5(H)mm<sup>3</sup>, 15kg

PSU-HPL-QS(12U)

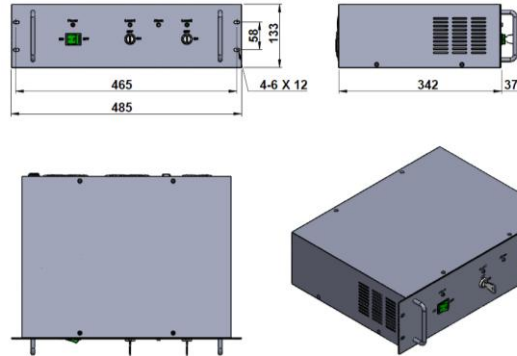

PSU-HPL-QS(12U)-2 485 (L) × 379(W) × 133(H)mm<sup>3</sup>, 14kg

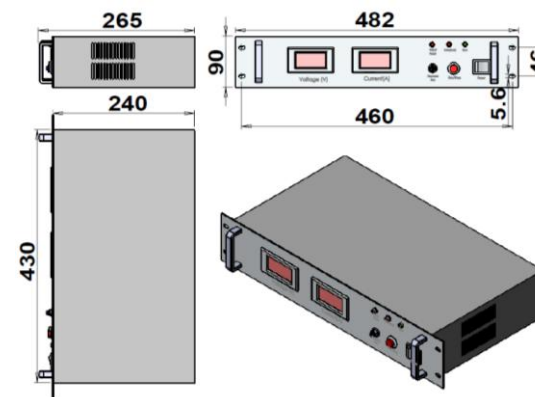

PSU-HPL-QS(12U)-3 482(L) × 265(W) × 90(H)mm<sup>3</sup>, 13kg

Water chiller

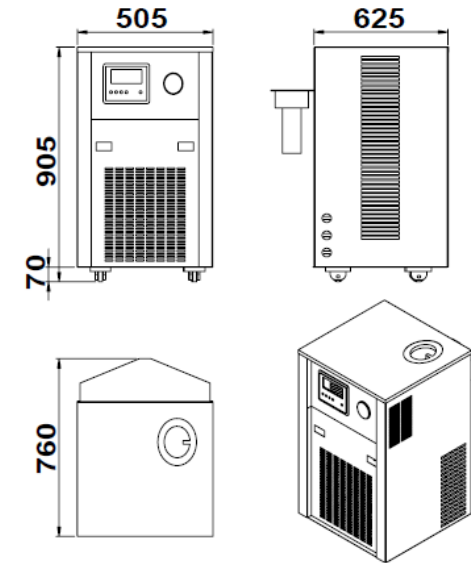

Water chiller 2 505 (L) × 760(W) × 905(H)mm<sup>3</sup>, 95kg