

MPL-III-1064/10~20uJ/1~500mW



**LD PUMPED ALL-SOLID-STATE
Q-SWITCHED LASER
AT 1064 nm**

All solid state Q-switched laser at 1064nm has the features of high peak power, high repetition rate, and short pulse duration, which is widely used in industry (marking on the diamond or stone), teaching of nonlinear optics, experiments of generating 532nm, 355nm, or 266nm laser, fiber communication, etc.



SPECIFICATIONS

Central wavelength (nm)		1064±1			
Operating mode		Q-switched pulsed laser			
Max average power (mW)		200	500		
Single pulse energy (μJ)		10~20			
Pulse duration (ns)		~1.3	3~5	5~10	10~25
Peak power (W)		7000~15000	2000~6000	1000~4000	400~2000
Rep. rate (kHz)	FIXED	Setting up one fixed rep. rate internal between 1k-4kHz with stable pulse energy, pulse duration and pulse period.			
	EXT TRIG	1Hz-4kHz by external trigger with stable pulse energy, pulse duration and pulse period.			
	QCW	QCW state with one rep. rate between 5k-20kHz.			
Average power (mW)		Average power (mW) = Single pulse energy (μJ) * Rep. rate (kHz)			
Ave power stability (over 4 hours)		<1%, <3%, <5%			
Transverse mode		TEM ₀₀			
Warm-up time (minutes)		<10			
M ² factor		<1.2			
Beam divergence, full angle (mrad)		<1.5			
Beam diameter at 1/e ² (mm)		~1.2			
Beam height from base plate (mm)		24.8			
Operating temperature (°C)		10~35			
Power supply (90-264VAC)		PSU-III-FDA			
Expected lifetime (hours)		10000			
Warranty		1 year			
Remarks		Average power of 1~2mW UV laser at 266nm or 355nm can be generated by MPL-III-1064 or MPL-III-532.			



MPL-III-1064

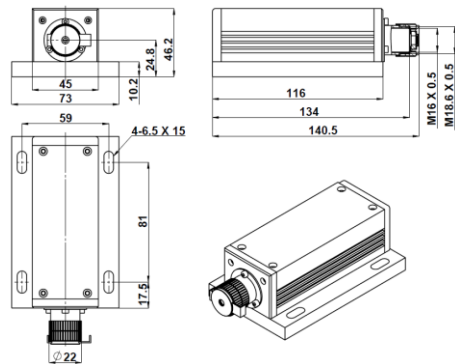

140.5 (L) × 73 (W) × 46.2 (H) mm³, 0.6kg

PSU-III-FDA

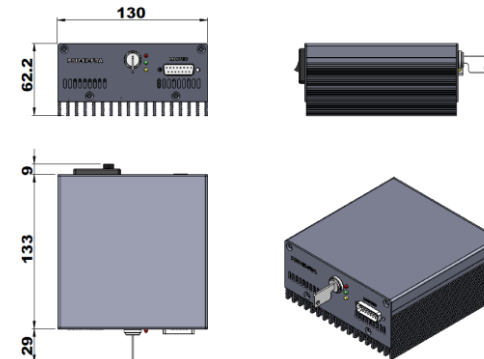

133 (L) × 130(W) × 62.2 (H) mm³, 1.2kg