

FC-W-520H-II/ 20~70W

SPECIFICATIONS

GREEN DIODE LASER AT
520nm

Green diode laser 520 nm is made features of ultra compact, long lifetime, low cost and easy operating. It's easy to be installed in customer's equipment.



Wavelength (nm)	520±5
Operating mode	CW
Output power (W) @ after 400um fiber	20~70 (Higher power can be customized.)
Cooled method	Water cooled
Fiber Core Diameter (um)	200, 400, 600...
Fiber Connector	SMA905/ FC/ QBH
Numerical Aperture (NA)	0.22
Power stability (rms, over 4 hours)	<1%, <3%...
Warm-up time (minutes)	<5
Beam height from base plate (mm)	99
Operating temperature (°C)	25+/- 3
Power supply	90-264VAC
Modulation option	TTL/Analog 1Hz-30KHz, TTL on/ off
Expected lifetime (hours)	10000

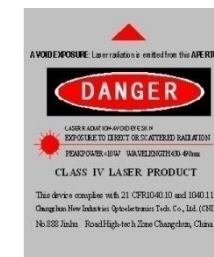

FC-W-520H-II (Water cooled)

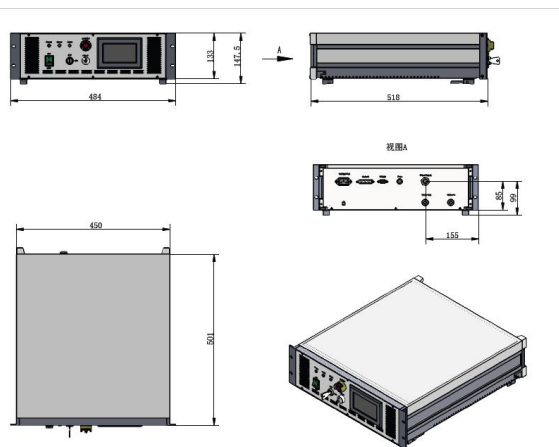

518 (L)×450(W)×147.5(H)mm³,

Water Chiller (WCH-370) (Optional)

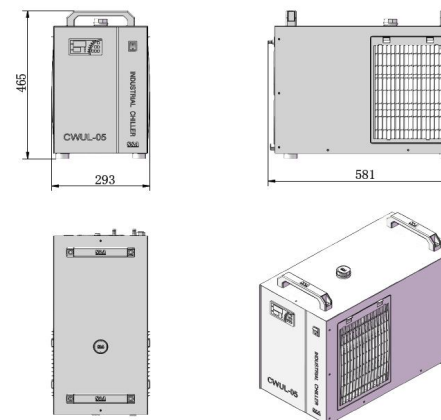

581(L)×293(W)×465(H)mm³,