

OEM-I-532 /1~5000mW

LD PUMPED ALL-SOLID-STATE GREEN LASER MODULE CORE

All solid state 532nm green laser module core is made features of ultra compact, long lifetime and easy operating. It's easy to be integrated into customer's equipment.



SPECIFICATIONS

Wavelength (nm)	532±1	
Operating mode	CW	
Output power (mW)	>1, 100, ..., 5000	
Power stability (rms, over 4 hours) at 25°C	<1%, <2%, <3%, <5%	
Transverse mode	Near TEM <sub>00</sub>	
Beam divergence, full angle (mrad)	~1.0	
Beam diameter at the aperture (mm)	~3.0	
Warm-up time (minutes)	<10	
Beam height from base plate (mm)	19 (OEM-I-532)	84.5 (I-532-HS)
Driver (12VDC 25A, power supply optional)	PSU-OEM-I	PSU-I-HS
TTL / Analog modulation	TTL or Analog with 1Hz-1kHz 1kHz-10kHz, 10kHz-30kHz optional	
Expected lifetime (hours)	10000	
Warranty period	1 year	

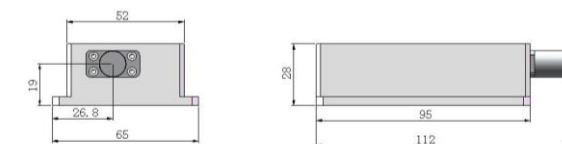
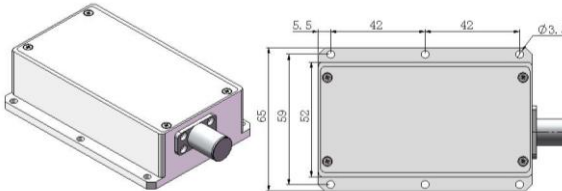
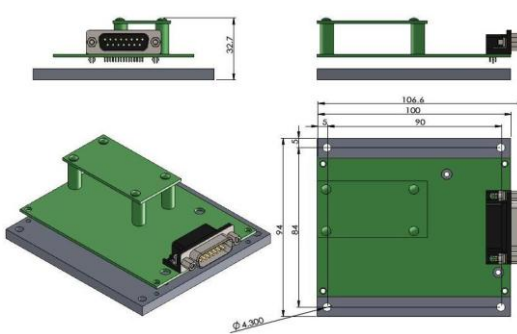
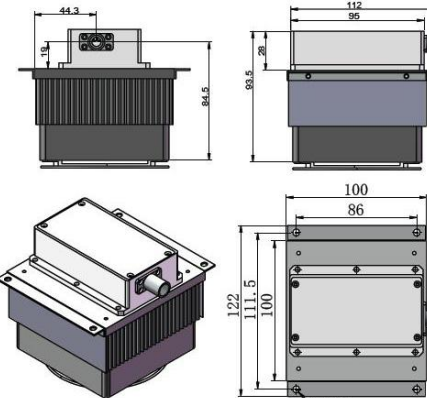
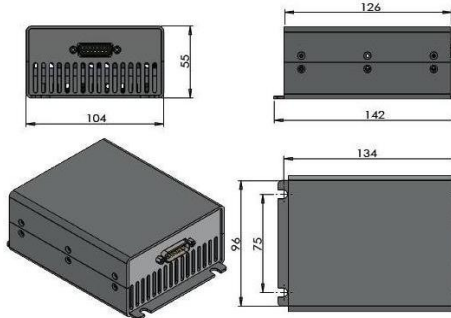

Note: The laser needs to be used on a heat sink with good heat dissipation.

OEM-I-532		I-532-HS	
Laser head	PSU-OEM-I (Driver)	Laser head	PSU-I-HS (Driver)
  <p>112 (L) ×65 (W) ×28 (H) mm<sup>3</sup>, 0.5 kg</p>	 <p>106.6 (L) ×94 (W) ×32.7 (H) mm<sup>3</sup>, 0.3 kg</p>	 <p>122 (L) ×112 (W) ×93.5 (H) mm<sup>3</sup>, 1.2 kg</p>	 <p>142 (L) ×104 (W) ×55 (H) mm<sup>3</sup>, 0.8 kg</p>