

PGL-D8-520/1~30mW

### HIGH POWER GREEN LASER MODULE AT 520 nm

PGL-D8 high power green laser module at 520nm is made features of small size, high output power, long lifetime, which made it widely used in collimation, laser medical treatment, scientific experiment, optical instrument and so on





#### SPECIFICATIONS

Wavelength (nm)	520±5
Operating mode	CW
Output power (mW)	>1,5, 10, ..., 30
Transverse mode	Multimode
Beam diameter at the aperture (1/e <sup>2</sup> , mm)	~2.0×4.0
Beam divergence, full angle (mrad)	~3.0×0.5
Operating temperature (°C)	15~30
Power supply	DC 7V PCB
Expected lifetime (hours)	10000
Warranty	6 months

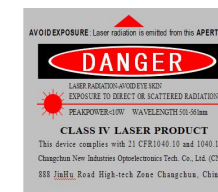
Note: The shell has non-polarity.

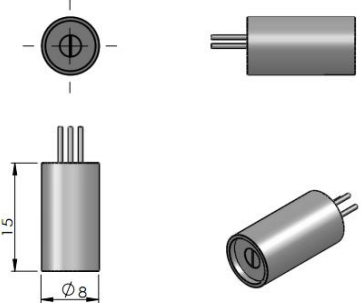

PGL-D8-520	Dimensions	7VPCB
 <p>Φ8×15(L) mm<sup>2</sup>, 1.5g</p>		 <p>17(L) × 11(W) mm<sup>2</sup></p>