

Acousto-Optic Frequency Shifters

Frequency shift device that superimposes ultrasonic frequencies on the input light

The **acousto-optic frequency shifter (AOFS)** are compact devices specifically designed to realize frequency shifts. The laser beam passes through all acousto-optic devices and the diffracted output beam is frequency shifted. Depending on the angle of incidence selected, the AOFS will shift up or down by the frequency of the applied RF signal and can be cascaded with two or more devices to achieve sum or difference combinations

Our team offers standard products with frequency shifts from 20-300 MHz, many of which can be realized in bicrystal devices. The frequency shifters utilize high acoustic and optical excellence Tellurium Oxide (TeO₂), which is grown and polished in-house at CASTECH to ensure the lowest insertion loss and high damage threshold.

CASTECH provides customized specs including center frequency and the shifted frequency value. Meanwhile, Foxchip is able to provide AOFS-matched series of RF inverter drivers, and the corresponding RF drivers can be selected according to product specifications.

CASTECH's products are produced independently throughout the entire process and can be customized according to customer needs. Refer to the following list for standard products.



Applications

- Interferometry
- Laser cooling
- Laser doppler velocimetry
- Optical heterodyne detection

Model Number: Free-Space Frequency Shifters CAFS-f-r-a-mt-w-c-h

Fiber-Coupled Frequency Shifters CAFSF-f-r-mtq-xb-w-c-h

Center Frequency (f)	RE Range (r)	Aperture (a)*	Material (m)	Mode(t)	Frequency-Mode (q)***	Fiber Type (a)**	Fiber Termina (b)**	Wave-length(w)	RF Connector (c)	Housing (h)
070 (70MHz)	10 (±10 MHz)	010 (1 mm)	CQ TE	C (Compressional) S (Shear)	D (Beat Frequency) S (Sum Frequency)	1(HI 1060) ...	B(Bare Fiber) F(FC/APC)	633 (633 nm) ...	AF (SMA-F) ...	A17 ...

* Only applicable to free space type **Only applicable to fiber coupled type ***Only applicable to coupled cascade combination type

Typical Specifications

Wavelength	Active Aperture	Operation frequency	Material
355-532 nm	1-3 mm	110 MHz	CQ
532 nm	2 mm	80 MHz	TE
633 nm	1-3 mm	20 MHz	TE
1064 nm	1 mm	70±15 MHz	TE
1550 nm	1 mm	110±10 MHz	TE
1550 nm	1.5 mm	80 MHz	TE

Housing dimensions(mm):

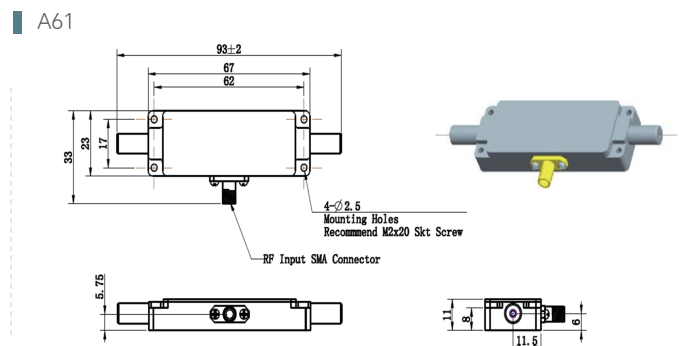
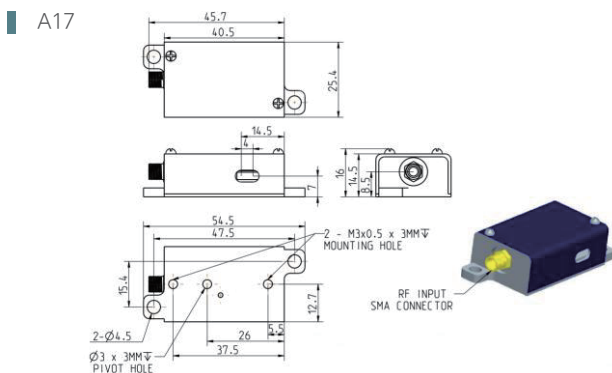

CASTECH, INC. / 018

Kokyo

株式会社 光響

Email : gs@symphotony.com

Web : https://www.symphotony.com/